

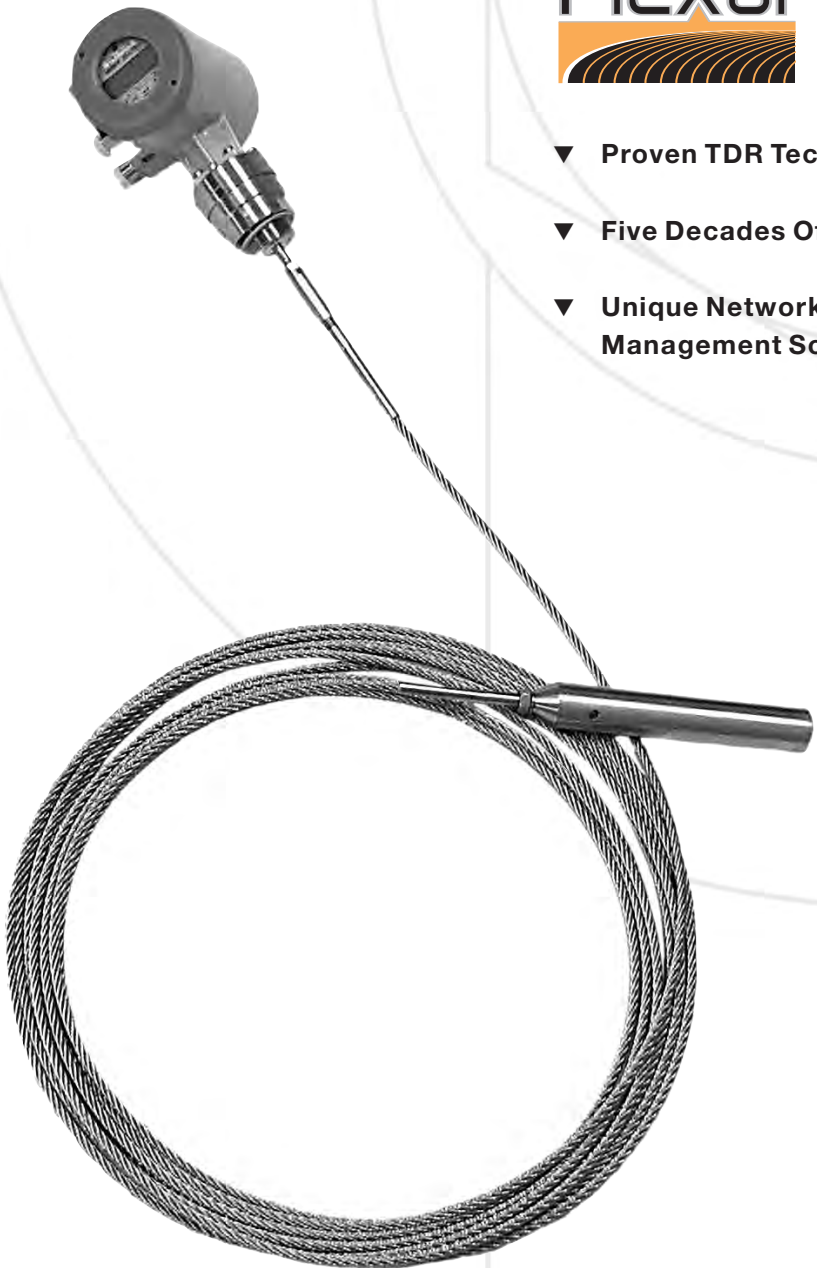

"Setting The Standard For Supplier Excellence"



Flexar™ Guided Wave Radar
Continuous Level
Measurement System

- ▼ Proven TDR Technology (Time Domain Reflectometry)
- ▼ Five Decades Of Application Expertise In Bulk Solids
- ▼ Unique Network-Ready PC-Based Inventory Management Software



- ▼ Proven Flexar™ Technology Installed In Thousands Of Bulk Solids Applications
- ▼ Reliable TDR (a.k.a Reflex Radar) Technology Used For Decades
- ▼ “Smart” Transmitter Output For Use With Industry-Leading SiloTrack™ Inventory Management Software
- ▼ SiloTrack Software Is Network-Ready – Virtually Unlimited Users (Local & Remote)
- ▼ Wireless Sensor Interface Available (Summer 2006)
- ▼ Measuring Range Up To 100ft (30m) In Solids And 200ft (60m) In Liquids
- ▼ Unaffected By Airborne Dust, Bulk Density, Temperature, And Other Properties – Ideal For Powders And Pneumatically Filled Solids
- ▼ Process Temperatures To +392°F (200°C)
- ▼ No Field Calibration Required - Easy To Install And Setup
- ▼ Optional Analog Output For Easy Connection To Existing Control Systems Or Indicating Devices
- ▼ Hazardous Location Approvals Available

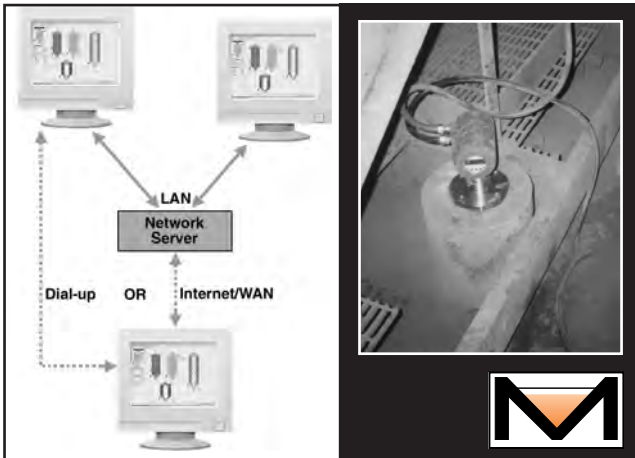

SiloTrack™

Flexar™ technology installed on Fly Ash/Coal Powder

Flexar™ Guided Wave Radar Continuous Level Measurement System

When All The Pieces Fit Just Right!

The Flexar™ continuous level measurement system is a smart guided wave radar device used for monitoring the level of powders, granules and other bulk solids. It is also suitable for use with a multiplicity of liquids. It is used in a wide assortment of vessels and industries for measuring levels up to 200ft (60m) in height.

Bringing the Pieces Together: Manufactured at our facility in Elburn, IL, we uniquely combine this proven and strategically acquired technology with almost five decades of expertise and focus in powder and bulk solids applications, and with our SiloTrack™ inventory management software interface. Monitor Technologies uniquely provides the best solutions in level measurement and inventory management of powders and bulk solids.

The Flexar sensor requires no field calibration or re-calibration and can be setup easily by customer personnel without the use of any special tools or training. Flexar units are suited for almost any application, can operate with process temperatures up to 392° F (200°C), can be provided with a variety of process connections and can work reliably with materials having a wide range of bulk densities and dielectric constants.

Flexar is available with a choice of two outputs. The standard output is a “smart” interface for use with SiloTrack™ Version 3.5 PC-based inventory management software. This network-ready software provides a flexible graphical interface for up to 128 “smart” output sensors. In lieu of this “smart” output, an optional analog output is also available.



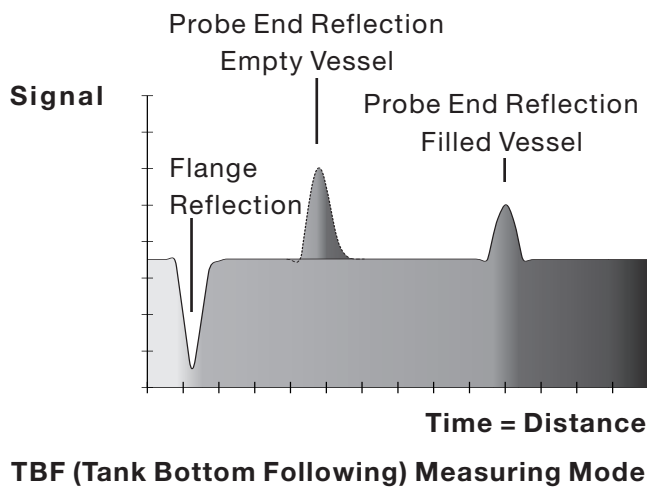
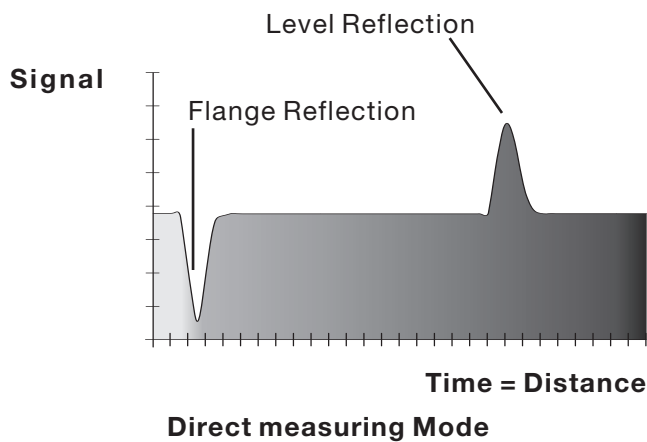

PRINCIPLE OF OPERATION

Flexar™ smart guided wave radar sensors operate using TDR (time domain reflectometry) principles that were first developed in the middle part of the 20th century for use in the geological field. Further development of TDR led to its use in the telecommunication industry for detecting breaks in cables. **Flexar** technology was pioneered in the mid-late 1990's when TDR was applied to level measuring applications within the process measurement industry.

In the application of TDR for process level measurement micro-pulses are continuously transmitted along a probe or "wave guide" at the speed of light. As soon as the pulses reach the material surface they reflect back to the sensor electronics unit. The time-of-flight of the pulses is calculated and directly related to the distance from the point at which the sensor is mounted on the top of the vessel to the material surface (level). The output from the electronics is continuously updated as the level of the material surface changes.

Flexar smart guided wave radar sensors are equipped with two different measuring modes. In the Direct measuring mode the pulses directly reflect off the material surface back to the electronics unit. This mode is used in applications where the material being measured has a dielectric constant as low as 2.1 for single-cable/rod probes and 1.8 for twin-cable probes.

For materials with dielectric constant below the above mentioned limits, down to as low as 1.4, the second measurement mode is used. This is the TBF (tank bottom following) mode, which is used due to the inability of the pulses to adequately reflect off of the surface of very low dielectric materials. In this measuring mode the **Flexar** sensor has a "short circuit" at the bottom of the probe at a precisely known distance from the sensor's mounting point.



In the TBF mode the pulses travel through air at the speed of light and then pass through the material in the vessel at a slower speed, dependent on the specific dielectric constant. The pulses are reflected at the short circuit back up the probe. Flexar sensors in the TBF mode measure the time between the emission and reception of the pulses from the probe short circuit. Because the return time of a pulse when no material is present (through air) is known, we can determine the difference in time between the time-of-flight when empty and the time-of-flight when filled as being directly proportional to the material level in the vessel.

Flexar™ technology measuring the level of a powder mixture for glass production



APPLICATIONS

The Flexar™ smart guided wave radar continuous level measuring system can be used in a wide variety of applications, including powders, coarse/fine granular solids, liquids, foodstuffs and even some corrosive substances. Flexar sensor technology is proven in many difficult applications including those where dust levels make it difficult for other technologies to perform reliably, especially at long ranges.



TYPICAL APPLICATIONS INCLUDE, BUT ARE NOT LIMITED TO:

Feeds	Bulk Chemicals
Cement	Plastic Pellets
Coal Dust	Aggregates
Lime	Oils
Powders	Fly Ash
Grains	Flour
Carbon Black	PVC Powder
Silica	

The maximum range for solids applications is limited to 100ft (30m) due to load limits possible from heavy materials in long ranges. Liquid applications can extend up to 200ft (60m). Any application requiring a continuous level measurement update where the process temperature does not exceed 392° F (200°C) and 580psig (40bar) is possible. The 316 stainless steel probes and threaded or flanged process connections make the Flexar continuous level measuring system ideal for almost any bulk solid and liquid application. To ensure a successful and reliable application, consult with the Monitor Technologies factory-based technical support group to see if Flexar is right for your application.

REMOTE INVENTORY MONITORING

If material levels need to be monitored at one or many locations (i.e. your facility, a location down the street, or a plant on the other side of the world) the Flexar system can provide continuous, reliable and accurate measurements. Using SiloTrack™ Version 3.5 software, inventory monitoring from remote locations has never been easier.



WIRELESS SENSOR COMMUNICATIONS INTERFACE

While using the Flexar "smart" sensor RS485 output is the most economical approach available, using the available wireless communications interface in your application may help you reduce the installed cost of your SiloTrack / Flexar system even further.

The wireless transceivers use frequency-hopping spread-spectrum wireless technology and operate in the FCC license-free 900MHz band. This provides the longest range and most reliable wireless communications available. This accessory item will be available for use with the Flexar sensor in Summer 2006 and may not be suitable in countries outside of North America.



FEATURES

▼ Solid-State Performance, No Moving Parts.

Unlike weight and cable based systems of old, Flexar™ guided wave radar sensors are state-of-the-art and use a time-proven electronic method for continuous measurement of a material level. This non-mechanical means of measurement helps ensure low maintenance.

▼ **Measure Materials With Dielectric > 1.4 (TBF Mode).** Flexar sensors are capable of sensing and measuring the level of most any material. Materials with dielectric constants below 1.8-2.1 require the use of our TBF (tank bottom following) measuring mode.

▼ **Unaffected By Dust And Changes In Material Properties.** The technology employed in Flexar units has been proven to be unaffected by airborne dust even during pneumatic filling operations. Unlike through-air technologies such as ultrasonic, through-air radar and laser, Flexar can reliably measure in dusty environments without sacrificing performance or reliability.

▼ Range Of Probes.

In order to handle the assortment of applications possible with Flexar, Monitor offers a range of probe styles including single-cable, twin-cable and single-rod. All probes are constructed of 316 stainless steel, have traction load handling capabilities suitable for their respective applications and are easily field replaceable. Consult with Monitor's factory-based technical support personnel to select the right probe style for your application.

▼ Assortment Of Process Connections.

To meet the required bulk solids and liquid applications we have prepared a selection of process connections that will ensure a smooth and simple installation. Flexar sensors can be provided with 1-1/2" NPT, 1-1/2" BSP G, 2" ANSI or DIN DN50PN40 flange connections. Probe type will determine the available process connections.

▼ Dual Compartment Enclosure.

The Flexar smart guided wave radar sensor uses an enclosure with two compartments, each with its own access cover. This allows separation of access for wiring and setup/display. The setup/display compartment is provided with a cover window allowing local viewing of the LCD display. In addition, every unit is provided with either two 1/2" NPT conduit entrances (NPT threaded and ANSI flanged process connections) or M20 cable connectors (BSP threaded and DN flanged process connections).



Flexar™ technology on lime silo



▼ **Local LCD Display And Setup.**

Each sensor includes a built-in user interface consisting of a three-line backlit LCD display, three pushbuttons and three magnetic sensors (used to perform setup and interact with the unit without having to remove the display cover).

▼ **Universal Power Supply.**

Power supply choices include a universal high voltage option 100-240 VAC and a low voltage 24 VAC/VDC option.

▼ **Choice of outputs.**

The standard output for all Flexar guided wave radar units is a “smart” RS-485 communications interface for use with SiloTrack™ Version 3.5 inventory management software. In lieu of this “smart” interface an analog 4-20mA output is available.

▼ **Remote electronics available.**

The standard unit includes the electronics integrally mounted with the sensor. However, remote mounted electronics is optionally available for applications where the electronics are desired to be mounted away from the probe due to extreme vibration, temperature or for convenient access to the local operator interface. The remote electronics version includes a pre-wired 16.4ft (5m) interconnecting cable.

▼ **Hazardous location approvals available.**

All units include the CE mark and are approved for use in ordinary locations. When required, Flexar sensors can be provided approved for use in hazardous areas worldwide. Flexar is available with ATEX and CSA_{US/C} approvals for hazardous areas.

PROBE STYLES

Single Cable 0.16” (4mm)

Single flexible 316 SS cable with counterweight

Vessel height ≤ 150ft (45m);
Liquids; Some solids
(consult Monitor)

Single Cable 0.31” (8mm)

Single Flexible 316 SS cable with counterweight

Vessel height ≤ 100ft (30m);
Powders and other bulk
solids (consult Monitor)

Twin Cable 0.16” (4mm)

Two flexible 316 SS cables with spacers between them at intervals, w/ counterweight

Vessel height ≤ 200ft (60m);
Low dielectric liquids, some
granules (consult Monitor)

Single Rod 0.38” (10mm)

Single 316 SS rigid rod

Vessel height ≤ 10ft (3m);
Liquids; Some powders
(consult Monitor)



PC-BASED INVENTORY MANAGEMENT SOFTWARE

SiloTrack™ Version 3.5 Inventory Management Software provides users with an unsurpassed, flexible graphical interface for Flexar™ smart guided wave radar sensors. Together, **SiloTrack** Server and Client software can provide inventory monitoring and management to a virtually unlimited number of users, both internal and external to your facility. This allows easy implementation of remote monitoring and vendor managed inventory programs.

SiloTrack capabilities include:

- ▼ Monitor up to 128 sensors/with up to 5 sensors per vessel
- ▼ Easy to setup and use
- ▼ Network-ready
- ▼ Remote monitoring via LAN, Internet/WAN or dial-up
- ▼ Available in English/Spanish language
- ▼ Automatic and manual measurement initiation
- ▼ Curve-fit weight table
- ▼ Enhanced 3-D type silo graphics
- ▼ Export silo history and alarm data
- ▼ Automatic Reports and Scheduling
- ▼ Set up four alarms per silo
- ▼ Alarm notification via e-mail, fax, and/or pager

Please refer to Bulletin 343B for additional information.

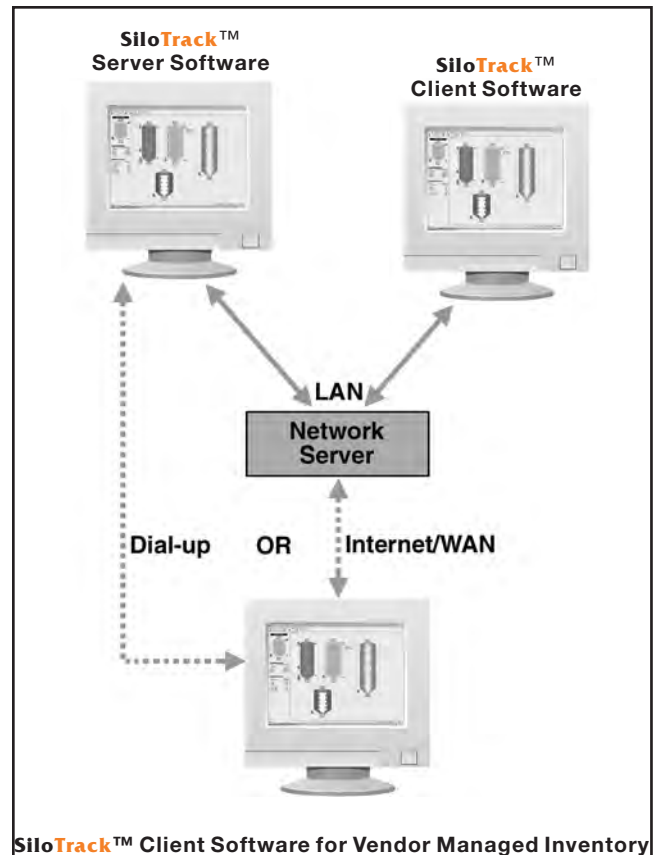

Remote and local monitoring of plastic storage at four facilities

SENSOR MECHANICALS

ORDINARY LOCATIONS

HAZARDOUS LOCATIONS

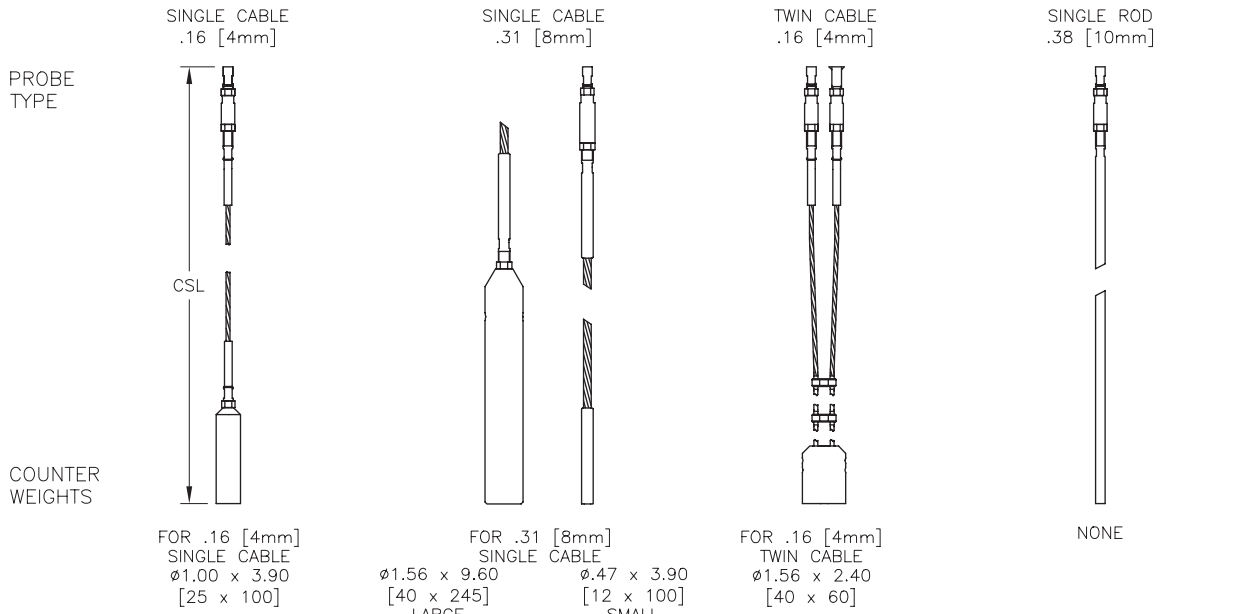
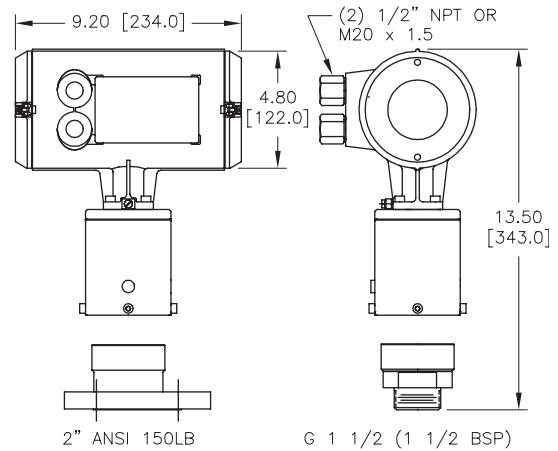
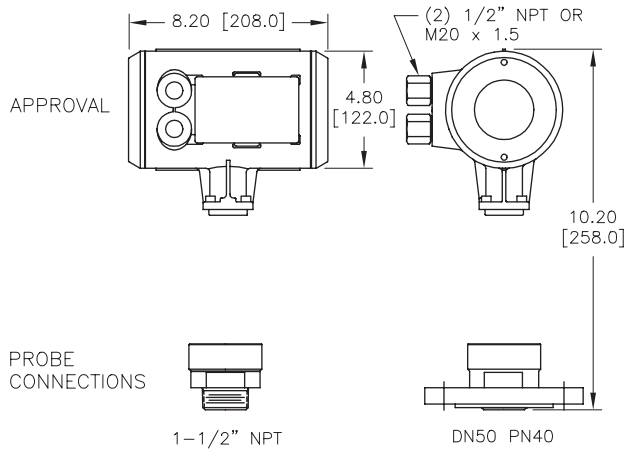

STD UNLESS SPECIFIED
 XX" [XXmm]



ORDERING INFORMATION

Flexar™ Guided Wave Radar¹

16 - 8 X X X - X X X X

ELECTRONICS TYPE

- 1 = Integral Electronics
- 2 = Remote Electronics⁵

OUTPUT

- 1 = "Smart" RS-485²
- 2 = Analog 4-20mA

COUNTERWEIGHTS

- 1 = For 0.16" (4mm) single cable
- 2 = For 0.31" (8mm) single cable, large CW
- 3 = For 0.31" (8mm) single cable, small CW
- 4 = For 0.16" (4mm) twin cable
- 5 = None required (rods only)

PROBE CONNECTION

- 1 = 1-1/2" NPT Threaded³
- 2 = G 1-1/2 (1-1/2" BSP) Threaded^{3,4}
- 3 = 2" ANSI 150lb Flange
- 4 = DN50PN40 DIN Flange

OPERATING VOLTAGE

- 1 = Universal High Voltage (100-240VAC)
- 2 = Low Voltage (24VAC/VDC)

APPROVALS

- 1 = Ordinary Location
- 2 = Hazardous Location CSA_{US/CA} (North America) (see specifications for details)⁵
- 3 = Hazardous Location ATEX (see specifications for details)⁵

PROBE TYPE⁷

- 1 = Single Cable, SS, 0.16" (4mm) Diameter
- 2 = Single Cable, SS, 0.31" (8mm) Diameter
- 3 = Twin Cable, SS, 0.16" (4mm) Diameter
- 4 = Single Rod, SS, 0.38" (10mm) Diameter

ACCESSORIES

16-3060	FLANGE, 2" ANSI 150 LB, 1-1/2 NPT ⁶
16-3062	FLANGE, DN50 PN40, 1-1/2 NPT ⁶
16-3064	FLANGE, 4" ANSI 150 LB, 1- 1/2 NPT ⁶
16-3066	FLANGE, DN100 PN40, 1-1/2 NPT ⁶
16-3070	FLANGE, K-STYLE, FLAT, 1 1/2 NPT ⁶
16-3072	FLANGE, K-STYLE, 10 DEG, 1 1/2 NPT ⁶

Note:

- 1 Consult Monitor Technologies factory for all applications prior to pricing and issuing quotation.
- 2 For use with SiloTrack V3.5 and higher
- 3 Single Cable/Rod Probes Only
- 4 Availability of G 1-1/2 threaded process connection is "pending". Consult factory.
- 5 Hazardous Location approval of Remote Electronics version is "pending". Consult Factory.
- 6 Flange accessories include a 1-1/2" NPT center hole for attaching to Flexar™ units with 1-1/2" NPT threaded process connection.
- 7 Customer specified length is from the bottom of the process connection to the bottom of the counterweight (end of rod on single rod probes).



SPECIFICATIONS

Power Requirements:	100-240VAC (+10%/- 15%); 9VA; 50/60Hz or 24VAC/VDC (+10%/- 15%); 9VA/W
Altitude:	6562ft (2000m) maximum
Installation Category:	II
Pollution Degree:	4 (reduced to 2 by enclosure) Suitable for indoor/outdoor use
Process Temperature:	
Ordinary Location Units	-20°F to +300°F (-30°C to +150°C);
Hazardous Location Units	-20°F to +392°F (-30°C to +200°C)
Ambient Temperature:	-5°F to +120°F (-20°C to +50°C)
Operating Pressure:	
1-1/2" NPT:	-14.5psig to +580psig (-1bar to +40bar)
G 1-1/2 (1-1/2" BSP):	-14.5psig to +580psig (-1bar to +40bar)
2" ANSI:	-14.5 psig to 150 psig (-1bar to 10bar)
DN50PN40:	-14.5psig to +580psig (-1bar to +40bar)
Measurement Range:	
Single Cable 0.16" (4mm):	150ft (45m)
Single Cable 0.31" (8mm):	100ft (30m)
Twin Cable 0.16" (4mm):	200ft (60m)
Single Rod .38" (10mm):	10ft (3m)
Accuracy:	
Direct Mode	
Solids	± 0.8" (20mm)
Liquids	< 20ft (6m): ± 0.2" (5mm) ≥ 20ft (6m): ± 0.2" (5mm) + 0.02% of distance measured
TBF Mode (All)	± 0.8" (20mm) when Dielectric is constant
Repeatability:	± 0.04" (1mm)
Resolution:	± 0.012" (0.3mm)
Minimum Dielectric Constant:	
Direct Mode	Twin Cable ≥ 1.8; Single Cable/Rod ≥ 2.1
TBF Mode	All Probe Styles ≥ 1.4
Process Mounting Connection:	
Single Cable/Rod Only	1-1/2" NPT; G 1-1/2 (1-1/2" BSP)
All probe Styles	2" ANSI 150lb. Flange; DN50PN40 Flange
Conduit/Cable Entry:	
NPT/ANSI Process Connections	(2) 1/2" NPT
BSP/DN Process Connections	(2) M20 x 1.5 cable connectors
Probe Styles:	
Single Cable	
0.16" (4mm)	316SS
0.31" (8mm)	316SS
Single Rod	316SS; 0.38" (10mm) diameter;
Twin Cable	316SS; Two 0.16" (4mm) cables; FEP spacers
Weight:	
Enclosure	18lb (8kg) without probe for ordinary location; 20lb (9kg) without probe for hazardous location;
Single Cable	
0.16" (4mm)	0.08lb/ft (0.12kg/m)
0.31" (8mm)	0.28lb/ft (0.41kg/m)
Single Rod	0.42lb/ft (0.62kg/m)
Twin Cable	double weight of 4mm cables above for twin cable
Maximum Traction Loading:	
0.31" (8mm) Single Cable	7,700lbs/3.9 tons (3.5 metric tons)
0.16" (4mm) Single Cable	2250lbs/1.1 tons (1.02 metric tons)
Minimum Separation From Objects:	
Single Cable/Rod	12" (300mm)
Twin Cable	4" (100mm)



Output Signal:	
"Smart":	RS-485, half-duplex, isolated, proprietary protocol
Analog:	4-20mA; 350ohms maximum load
Wiring Distance ("smart" output):	4,000ft (1,220m)
Local Display:	3-line; Backlit LCD; 3 pushbuttons; 3 magnetic sensors for setup without cover removal
Materials of Construction:	
Enclosure:	Aluminum, powder coated
Threaded/Flange Connection:	316 Stainless Steel
Process Insulator:	Teflon (PTFE)
O-Ring Seal:	Viton
Probes:	316 Stainless Steel
Remote Electronics:	16.4' (5m) pre-wired interconnection cable
Dead Zones:	
Single Cable/Rod	
Dielectric = 80 (water)	Top = 15.75" (400mm) Bottom = 0.8" (20mm)
Dielectric = 2.4 (oil)	Top = 19.7" (500mm) Bottom = 3.9" (100mm)
Twin Cable	
Dielectric = 80 (water)	Top = 9.8" (250mm) Bottom = 0.8" (20mm)
Dielectric = 2.4 (oil)	Top = 13.0" (330mm) Bottom = 0.8" (20mm)
Enclosure Rating:	NEMA 4, IP66
Approvals:	
Integral Electronics Only	
Ordinary Location	CE Mark
Hazardous Location	CSA _{US/IC} Class I, Div 1,2, Groups B, C, D; Class II, Div 1,2, Groups E, F, G; Class III ATEX Ⓜ II 1/2 GD T75...150C
Remote Electronics	
Ordinary Location	CE Mark
Hazardous Location	ATEX Ⓜ II 1/2 GD T75...150C

WARRANTY

Monitor Technologies LLC warrants each Flexar™ guided wave radar continuous level measurement system it manufactures to be free from defects in material and workmanship under normal use and service within two (2) years from the date of purchase. The purchaser must give notice of any defect to Monitor within the warranty period, return the product intact and pre-paid transportation charges. The obligation of Monitor Technologies LLC under warranty is limited to repair or replacement at its factory. This warranty shall not apply to any product which is repaired or altered outside of the Monitor Technologies LLC factory, or which has been subject to misuse, negligence, accident, incorrect wiring by others or improper installation.

Monitor Technologies LLC reserves the right to change the design and/or specifications with our prior notice.





44W320 Keslinger Road ▼ P.O. Box 8048 ▼ Elburn, IL 60119-8048 ▼ 800-766-6486 ▼ 630-365-9403 ▼ Fax 630-365-5646
www.flexar.info ▼ www.monitortech.com ▼ monitor@monitortech.com

